

TECHNICAL MANUAL

**OPERATOR, ORGANIZATIONAL, DIRECT SUPPORT
AND GENERAL SUPPORT MAINTENANCE
MANUAL INCLUDING REPAIR PARTS LIST**

FOR

**BALANCER, WHEEL VEHICLE: ELECTRONIC
MODEL 814
(4910-00-279-0629)**

HEADQUARTERS, DEPARTMENT OF THE ARMY

MARCH 1983

WARNING

Remove all foreign objects from tire.

Due to strobe light effect the wheel appears stationary or not moving. Keep hands, arms, body and tools away from tire while spinning.

Make sure strobe unit is not plugged into electric outlet.

Technical Manual }
No. 9-4910-625-14&P }

HEADQUARTERS
DEPARTMENT OF THE ARMY
Washington, DC, 14 March 1983

**OPERATOR'S, OPERATIONAL, DIRECT SUPPORT
AND GENERAL SUPPORT MAINTENANCE MANUAL
INCLUDING REPAIR PARTS LIST
FOR
BALANCER, VEHICLE WHEEL
MODEL 814
(NSN 4910-00-279-0629)**

REPORTING ERRORS AND RECOMMENDING IMPROVEMENTS

You can help improve this manual. If you find any mistakes or if you know of a way to improve the procedures, please let us know. Mail your letter, DA Form 2028 (Recommended Changes to Publications and Blank Forms), or DA FORM 2028-2, located in the back of this manual direct to: Commander, US Army Armament Materiel Readiness Command, ATTN: DRSAR-MAS, Rock Island, IL 61299.
A reply will be furnished directly to you.

NOTE

This manual is published for the purpose of identifying an authorized commercial manual for the use of the personnel to whom this equipment is issued.

Manufactured by: Titan Industries
11011 Wye Drive
P. O. Box 32417
San Antonio, TX 78216
Procured under Contract No. DAAA09-76-6889

This technical manual is an authentication of the manufacturers' commercial literature and does not conform with the format and content specified in AR 310-3, Military Publications. This technical manual does, however, contain available information that is essential to the operation and maintenance of the equipment.

INSTRUCTIONS FOR REQUISITIONING PARTS

NOT IDENTIFIED BY NSN

When requisitioning parts not identified by National Stock Number, it is mandatory that the following information be furnished the supply officer.

- 1 - Manufacturer's Federal Supply Code Number. 3M032
- 2 - Manufacturer's Part Number exactly as listed herein.
- 3 - Nomenclature exactly as listed herein, including dimensions, if necessary.
- 4 - Manufacturer's Model Number. 814
- 5 - Manufacturer's Serial Number (End Item).
- 6 - Any other information such as Type, Frame Number, and Electrical Characteristics, if applicable.
- 7 - If DD Form 1348 is used, fill in all blocks except 4, 5, 6, and Remarks field in accordance with AR 725-50.

Complete Form as Follows:

- (a) In blocks 4, 5, 6, list manufacturer's Federal Supply Code Number - 3M032 followed by a colon and manufacturer's Part Number for the repair part.
- (b) Complete Remarks field as follows:
 - Noun: (nomenclature of repair part)
 - For: NSN: 4910-00-279-0629
 - Manufacturer: Tital Industries
11011 Wye Drive, P.O. Box 32417, San Antonio, TX 78216
 - Model: 814
 - Serial: (of end item)

Any other pertinent information such as Frame Number, Type, Dimensions, etc.

INTRODUCTION

The Electronic -on-vehicle wheel balancer will balance passenger car and truck wheels quickly, with no wheel attachments. Balancer is ideal for balancing wheels on which conventional adapters cannot be mounted, such as mag or sport wheels. Wheel is statically balanced, and may be dynamically balanced by using optional dynamic balancing accessory.

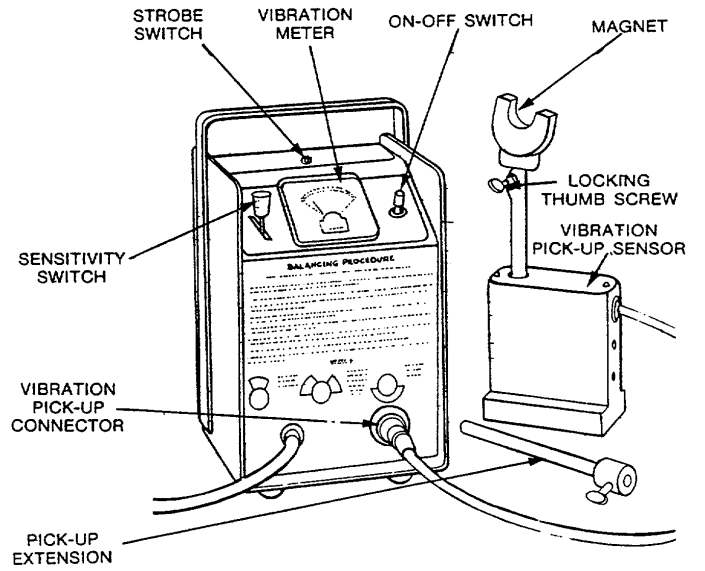

Figure 1. Electronic Balancer

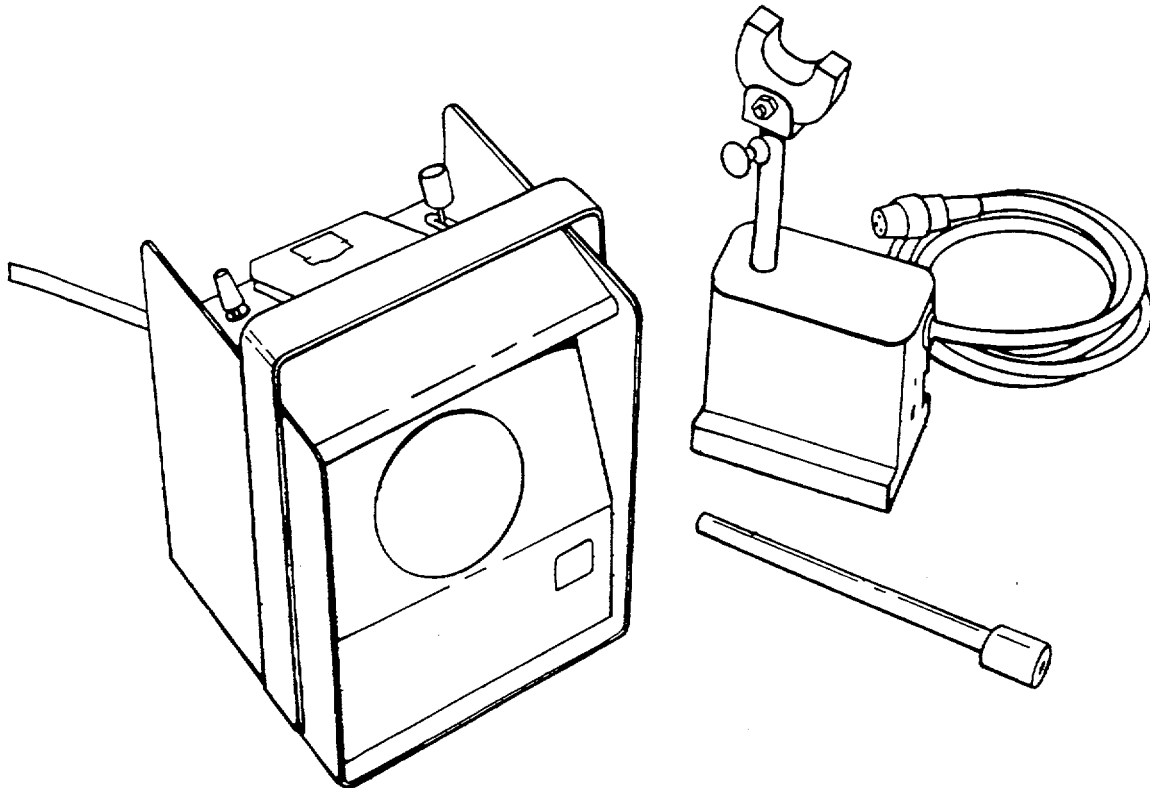

Figure 2. On-Vehicle Electronic Wheel Balancer

DESCRIPTION

The Electronic Wheel Balancer is designed for balancing wheels on the vehicle. The balancer consists of two assemblies: a strobe unit containing the meter, strobe lamp, printed circuit board and power transformer; and a vibration pick-up assembly that connects to the strobe assembly by a multi-conductor cable and connector. The strobe assembly has a 3 conductor power cord that plugs into a 120 volt, 60 Hertz outlet. A one ampere 3 AG fuse is held in a fuse clip adjacent to the power transformer.

contains most electronic components except switches, flashtube, meter and transformer assemblies.

The vibration pick-up assembly board (60265) contains three electronic components and solder terminals for lead connections. The three are a buffer amplifier, light emitting diode and a resistor. The light sensor potentiometer is part of the vibrating block assembly. Refer to principles of operation and the schematic for details of circuit operation.

Each assembly has a printed circuit board which is non-serviceable. The strobe assembly board (60589)

PRINCIPLES OF OPERATION

The following text and drawings are intended to familiarize the service technician with the unit circuitry as it is applied to balancing a vehicle wheel. The drawing below has been simplified to show clearly the vehicle and balancer components.

by means of its spring suspension system (5). The vibration pick-up assembly (6) has the magnet-rod assembly (7) adjusted by thumb screw (8) so the U magnet is in firm contact with a flat surface on the lower suspension member. See Figure 2 for detail of the vibration pick-up.

Normal wheel balancing procedure requires the wheel to be spun to approximately 60 to 70 MPH with a wheel spinner. The strobe unit meter reading (9) will rise as wheel speed increases. When the meter pointer reaches its peak rise (resonant point), it will start to drop. At this point, the spinner is disengaged and the meter observed. As the wheel speed decreases and again passes through the resonant point, the meter pointer will rise. When the pointer starts to drop off, the Strobe button is pushed and the location of a reference mark on the wheel noted. This reference is used by the operator for determining placement of balancing weights. The procedure is repeated until the meter reading is in the green zone with the meter sensitivity switch in the high position.

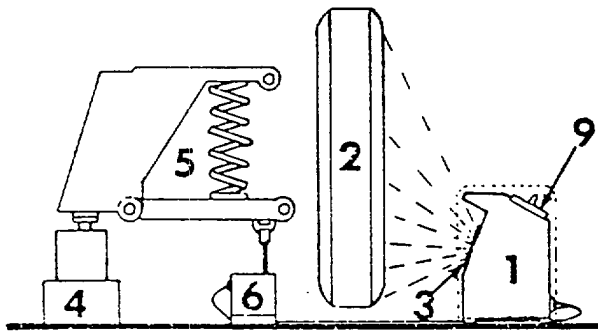

Figure 3. Balancer Hook-up

Figure 3 shows the balancer strobe unit (1) positioned to the side of a vehicle wheel (2). The strobe flashtube (3) is directed at the wheel. The vehicle frame is elevated by the jack (4) so the wheel is supported above the floor

PRINCIPLES OF OPERATION (cont.)

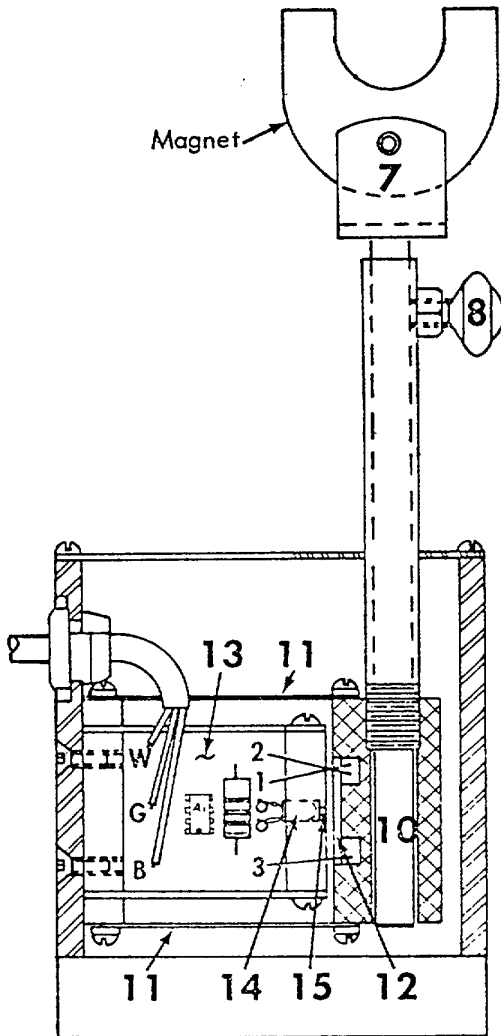

Figure 4. Item 6, Vibration Pickup Ass'y

A wheel out of balance will impart vertical vibrations to the magnet-rod assembly (7) on the vibration pick-up. The vibrations are transferred to the movable block-potentiometer assembly (10) suspended by two leaf springs (11) shown in figure 4. The light sensor potentiometer (12) is epoxied into a vertical slot of the block and has three flexible leads connected to the pc board (13). When the block vibrates up and down, light from a light emitting diode (14), transmitted through a slit (15), strikes different vertical positions of the light sensor pot. This action causes the output voltage of the light sensor to vary in a regular cyclic manner. The output voltage is generally sinusoidal, and is proportional to the amount of unbalance producing the vibration.

The generated sinusoidal voltage is coupled to a buffer amplifier (reference A1 on schematic), and is located on pc board (13) in the vibration pick-up assembly. The output of A1 is connected to its inverting input to provide negative feedback. The output is also coupled by wire 15 to meter amplifier A2 via an ac coupling network, C1 and R2. The meter amplifier modifies the input signal so as to adequately drive amplifier A3 and the meter through full wave rectifier DB1. Offset null pot R3 provides zero-balance adjustment of the output. Connected to the inverting input of A2 and the bridge is the meter sensitivity switch and three resistors R4, R5 and R6 for selecting amplifier gain.

PRINCIPLES OF OPERATION (cont.)

A sinusoidal signal in synchronism with the vibrations of the vehicle suspension system appears at the output of A2. See figure 5. This signal is inverted and converted to a square wave by amplifier A3. The square wave signal is differentiated by capacitor C2 and resistor R7 to produce sharp positive and negative pulses at the base of transistor Q1. Transistor Q1 will conduct only on the positive pulse, and thus triggers SCR (Q2) on when the strobe switch is closed. When Q2 turns on, it effectively connects capacitor C3 to ground, causing C3 to discharge through a trigger coil (part of the flash tube) and flash the strobe light. The strobe is flashed as the wheel passes through the midpoint of its downward vertical

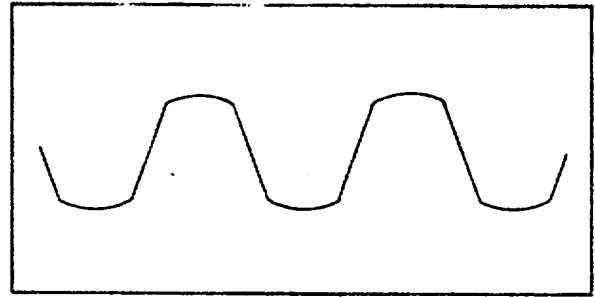

Figure 5. Sinusoidal signal Waveshape

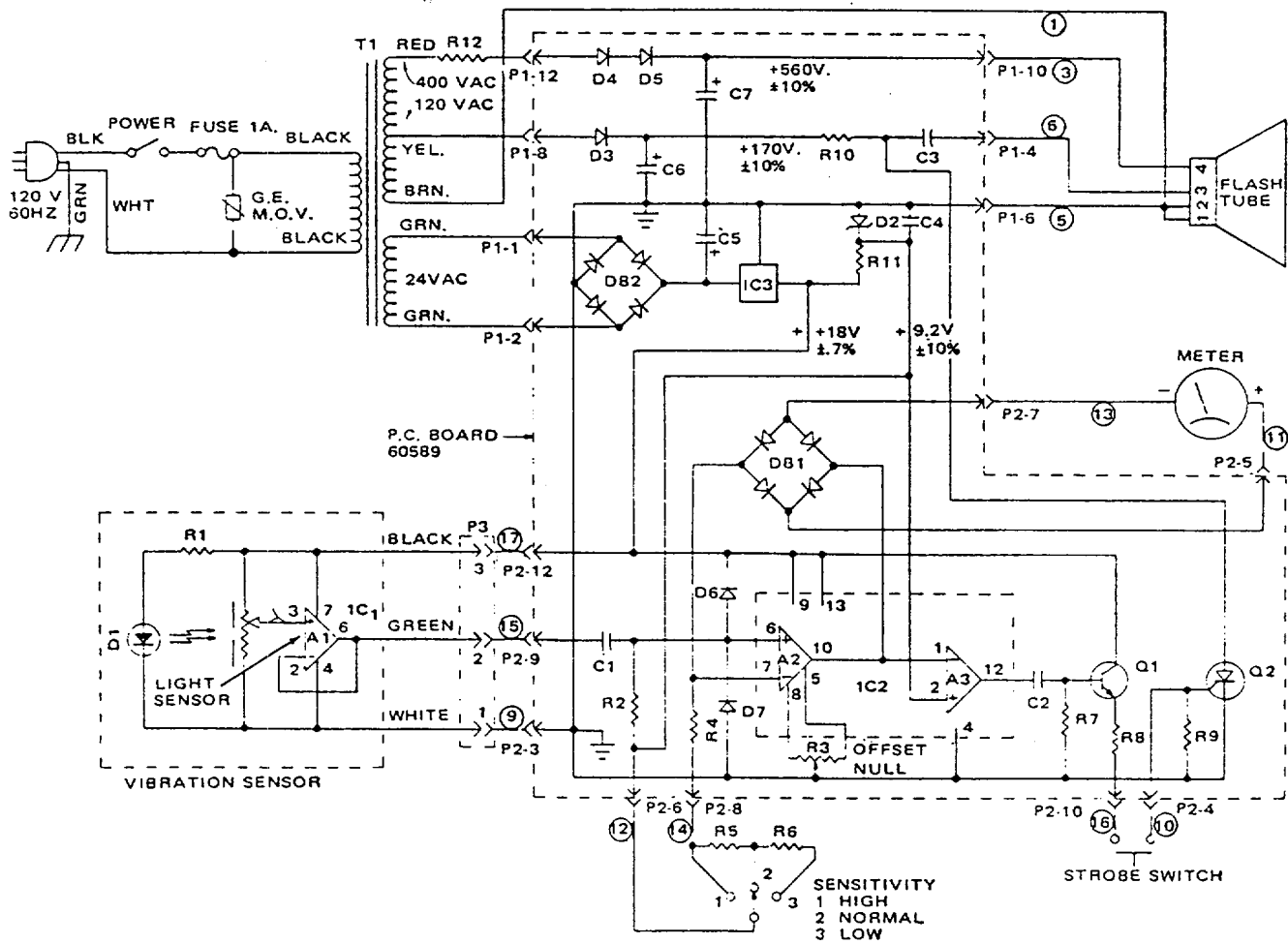

Figure 6. Schematic

BALANCING FRONT WHEELS

1. Using a service jack under front crossmember, raise vehicle so both front wheels are at least one inch off the floor. Make sure steering wheel is locked or steering wheel holder is used.

NOTE : *It is good safety practice to use jack stands to support vehicle for all on-vehicle balancing.*

2. Check for loose wheel bearings, excessively loose suspension and dragging brakes, and correct before balancing wheel.
3. Remove all weights from both sides of the wheel, unless you are finish balancing a wheel that has been previously balanced on an off-vehicle dynamic balancer.

WARNING: Remove all foreign objects from tire.

NOTE: *Remove hub cap or wheel cover if necessary, to remove or install wheel weights.*

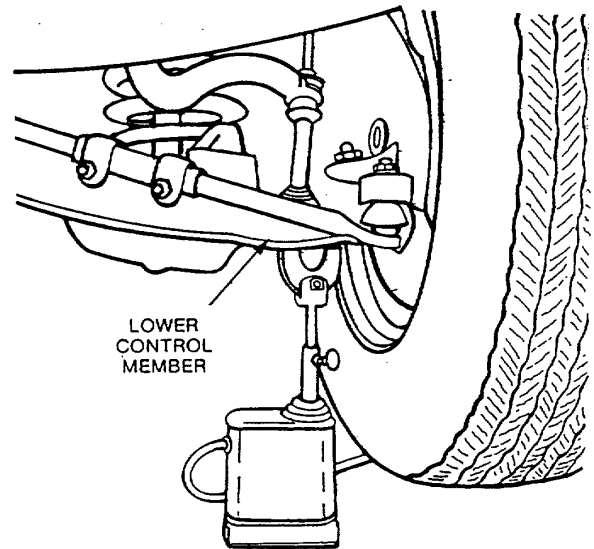

Figure 7. Vibration Sensor Installed

necessary to back off the disc brake pads or to determine the cause of wheel drag.

NOTE: *If the meter reading does not exceed 1 with wheel spinning freely and the sensitivity switch at NORMAL,, move the sensitivity switch to the HIGH position. If, on the other hand, the meter reading is at maximum indication on the scale, move the sensitivity switch to the LOW position.*

4. Place vibration sensor on level surface, under lower control member. Loosen locking thumb screw and position magnet in firm contact with the lower control member. Magnet should be as close to the wheel being balanced as possible. Securely lock the thumb screw on the pickup. See figure 4.

5. Connect vibration pick-up to balancer and plug balancer unit into 110 volts; 60 Hz grounded outlet and switch balancer to ON. If using Spinner, balancer may be plugged directly into spinner socket.

CAUTION: Make certain that the vibration pickup cord will not contact the spinning wheel.

NOTE: *During balancing do not allow anyone to lean on, sit in or otherwise to disturb the vehicle as this would adversely affect the balancing.*

6. Place balancer sensitivity switch on NORMAL setting.

7. Place a chalk mark or a piece of tape on the tire at a random point, or establish some other convenient reference mark, such as the valve stem. See figure 9.

8. Using a spinner, spin the wheel at 60 to 70 MPH. Then back off the spinner and allow the wheel to spin freely. If the spinner does not have enough power to achieve 60 to 70 MPH, may be

9. With the wheel spinning freely, observe the maximum meter reading.

10. Keep your attention focused on the meter scale until the needle just starts to drop off from the maximum reading.

11. Depress the strobe switch. With the strobe switch depressed and the needle just starting to drop off from maximum reading, note the position in which the reference mark appears to be stopped on the rotating wheel.

WARNING: Due to strobe light effect the wheel appears stationary or not moving. Keep hands, arms, body and tools away from tire while spinning.

12. Now bring the wheel to a stop and place the reference mark in the same position in which you observed it with strobe light, while the wheel was spinning in the previous step.

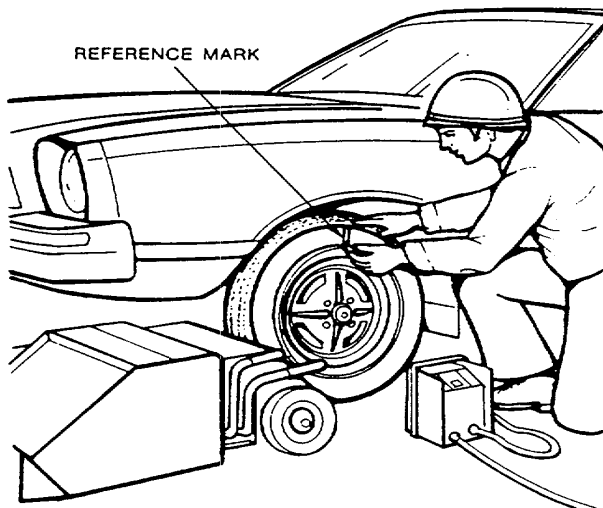

Figure 9. Reference Mark Tire

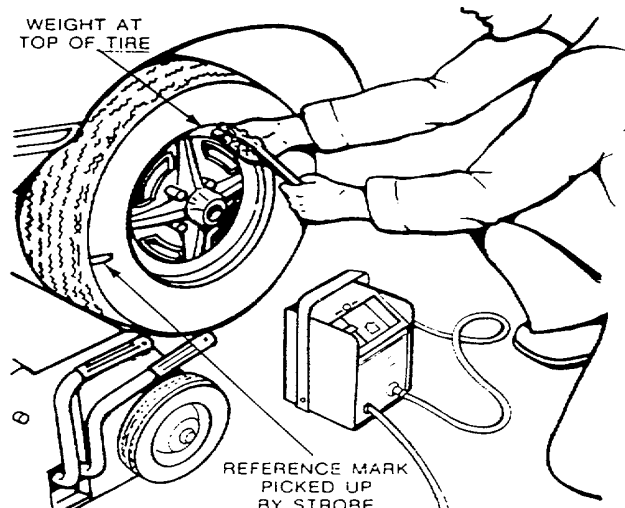

Figure 10. Applying Initial Weight

13. With the reference mark in this correct position, apply the INITIAL WEIGHT to the top position of the wheel, figure 6. While the selection of the initial weight depends somewhat on judgement, experience and feel, a good starting point is 1-1/2 ozs.
14. Repeat steps 8 through 13, except observe position of INITIAL WEIGHT, not reference mark. Refer to Figure 8 for amount of weight change and placement of weight.
15. Continue to repeat steps 8 through 14 until the meter reading is in the green area with the sensitivity switch on HIGH. At this point, the wheel will have satisfactory static balance for normal road conditions.

NOTE: *It is good balancing practice to split the weight and place one-half of the weight on the inside of the wheel and one-half on the outside. It will save time, however, if all the weight is initially placed on the outside of the wheel and proper balance is obtained. Then the weight should be split and a final test spin made with any needed corrections made to the outside weight only.*

16. If the vehicle has full disc wheel covers so that it's impossible to add or remove weights with the wheel cover in place, replace the wheel cover at this point and repeat steps 8 through 15, except that the weights are added on the inside of the wheel instead of the outside. Because wheel cover unbalance is usually quite small, a 1/2 or 1/4 oz. correction weight is a good starting point for the initial amount of weight to be added.

NOTE : *Make sure vibration pickup is still in contact with lower control arm after installing weights.*

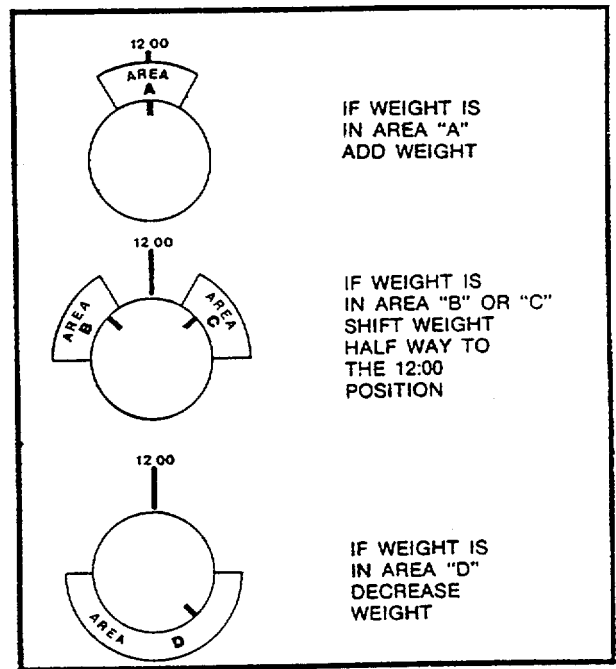

Figure 8. Weight Positioning and Movement

SPECIAL APPLICATION BALANCING

STANDARD DIFFERENTIAL

Rear wheels of cars with a standard differential can be balanced on the rear, using the following modifications to the front wheel balancing procedure.

1. Raise vehicle by jacking under the frame so that only the rear wheel to be balanced is freely suspended.
2. Connect the vibration pickup unit to the rear axle housing as close as possible to the wheel to be balanced.

3. Have an assistant drive the vehicle at a constant 35 MPH as indicated on the vehicle's speedometer. (The raised wheel is actually moving at twice the indicated speed.)

NOTE: *Refer to Balancing Rear Wheels on Front Drive Vehicles when vehicle is-a front drive.*

4. Follow the front wheel balancing procedure from step 10 through step 16. When balancing rear wheels, the sensitivity switch needs only be set on NORMAL setting.

LIMITED SLIP OR POSITIVE DRIVE DIFFERENTIALS

With a limited slip differential, it will be necessary to remove the wheel opposite the wheel being balanced to prevent the unbalanced forces of the unbalanced wheel from being transmitted to the wheel being balanced.

1. With floor jack placed securely under frame raise one rear wheel at least 2" off the floor. Remove wheel and replace wheel nuts to hold drum in place. (Wheel nuts should be reversed so flat face contacts drum and should be tightened until snug--DO NOT USE IMPACT WRENCH.) Install safety stand under rear axle housing and lower vehicle onto safety stand.
2. With floor jack placed securely under frame, in front of rear wheel, raise the other wheel at least 2" off the floor. Place vehicle on safety stand.
3. Connect the vibration sensor to the rear axle housing as close to the wheel to be balanced as possible.
4. Have assistant put car in high gear and slowly accelerate until a maximum of 70 MPH speedometer reading is obtained. Hold accelerator at a constant speed.
5. Follow the front wheel balancing procedure from step 9 through step 16.
6. Replace wheel that was removed and balance wheel in the same manner.

NOTE: (Wheel that was balanced first can be left on the vehicle because it has already been balanced and will not set up any vibration when balancing the opposite wheel.)

CAUTION: Never drive wheels in excess of maximum speed listed or longer than 2 minutes as internal vehicle damage may result.

BALANCING FRONT WHEELS ON FRONT DRIVE - VEHICLES

1. Place service jack under lower control arm and raise the wheel approximately 1" off the floor.
2. Have assistant run motor in drive position until a maximum of 35 MPH speedometer reading is obtained.
3. Balance the wheel as outlined previously.

BALANCING REAR WHEELS ON FRONT DRIVE VEHICLES

1. Place service jack under center of rear housing and raise wheels approximately 1" off the floor.
2. Position wheel spinner at rear of wheel and spin at approximately 60 to 70 MPH.
3. Balance the rear wheel as outlined previously, for front wheels.

DYNAMIC BALANCING

The optional dynamic balancing adapter (Part No. 60690) mounts the vibration sensor of the Model 800 electronic on-vehicle wheel balancer in the correct plane for dynamic wheel balancing. If a wheel has been balanced on the car using the normal balancing procedure, and there is still a vibration, it should then be checked for dynamic unbalance.

NOTE: Make sure wheel is statically balanced before proceeding with dynamic balance.

1. Jack vehicle up as in normal balancing procedure.
2. Rotate the steering wheel so the wheel to be balanced is about a quarter turn from its outer limit. This allows access to a vibration sensor pickup location. Lock the steering wheel in this position with a steering wheel holder. or steering column lock.

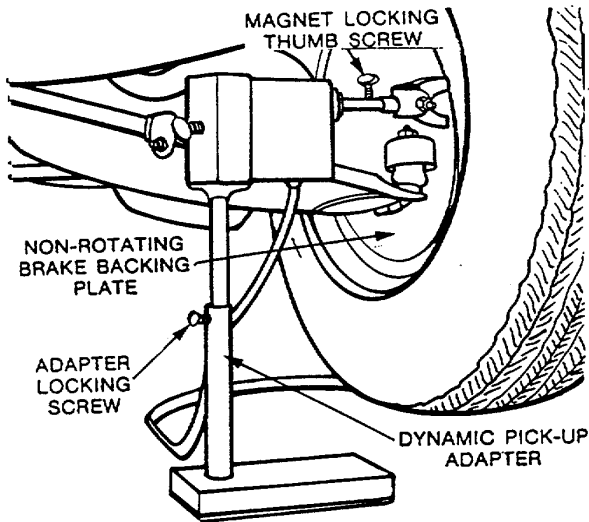

Figure 11. Dynamic Balancing Adapter

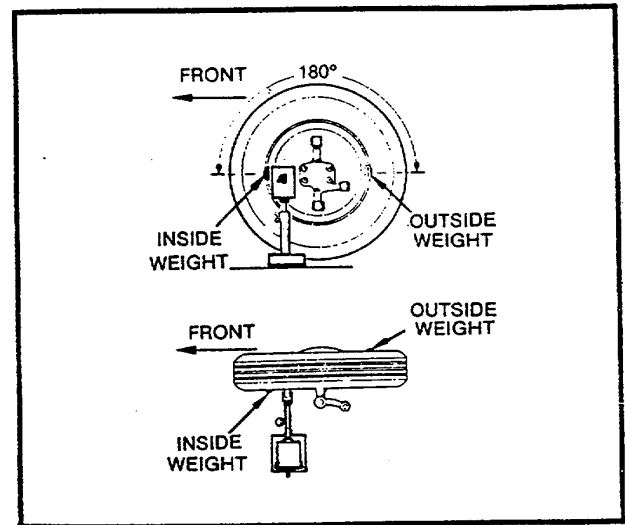

Figure 12. Dynamic Split Weight Installation

3. Insert vibration sensor into adapter so cable extends downward, figure 11. Tighten locking screw to hold sensor securely.
4. Loosen locking screw on adapter extension tube Figure 11, and adjust height so magnet is at spindle height if possible. Tighten locking screw.
5. Loosen magnet locking thumb screw on vibration sensor. Position complete unit so magnet assembly can be extended to contact front portion of brake backing-plate cover directly in front of and in line with the spindle, figure 11. The magnet rod should be parallel to wheel spindle. Tighten locking screw down on magnet rod.

NOTE: Make sure magnet is NOT connected to a rotating brake component.

9. Spin the wheel at half speed again. The tire is dynamically balanced if the meter is in the green. If the meter is not in the green, spin the wheel again as in step 7 and note the position the dynamic weight on the outer rim. Refer to figure 13 for relocating or changing the size of the dynamic weights.
10. Repeat step 9 until the meter indicates an acceptable amount of vibration.

6. Spin wheel to one half the speed used for normal balancing. If meter indicates in the green with Normal sensitivity, the dynamic balance is acceptable.
7. If meter does not indicate an acceptable level of balance, spin wheel until meter peaks, allow it to coast down and as needle drops from peak, press strobe switch. Note location of reference mark as in normal balancing procedure.
8. Brake wheel. Rotate wheel until reference mark is in location noted in step 7 above. Place a three (3) ounce weight on the most forward point of the inside rim. Place 3 ounce weight on the outside rim, 180S from the first weight. See figure 12.

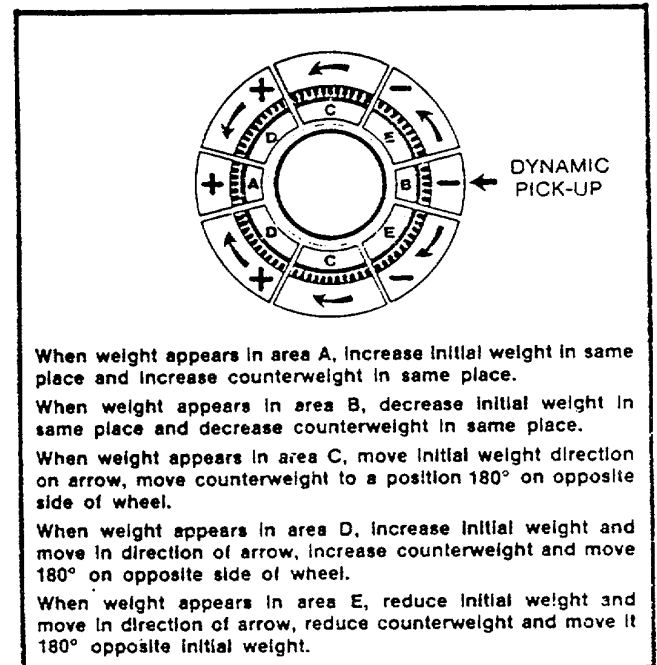

Figure 13. Dynamic Weight Positioning and Movement

TRUCK WHEEL BALANCING

The vibration sensor comes equipped with an extension rod which enables the electronic balancer to be used on large trucks. The same balancing procedures apply to trucks and cars. The only difference is the sensor extension rod may be needed to reach the truck axle and 7.5 hp truck spinner to turn the large wheels.

Raise solid axle trucks with jack under axle.
 Raise independent suspension trucks the same as cars.
 Vibration sensor is connected to the axle as close to the wheel as possible.

TROUBLESHOOTING		
TROUBLE	CAUSE	REMEDY
Meter reading off scale with sensor disconnected	Defective circuit board	Forward to Organizational Maintenance
Meter responds to vibration sensor but strobe does not flash	a) Defective strobe switch b) Strobe tube defective c) Circuit board defective	Forward to Organizational Maintenance <p style="text-align: center;">Replace strobe light</p> Forward to Organizational Maintenance

MAINTENANCE

The only maintenance required is normal care and cleaning. Periodically inspect the line cord and the sensor cable for damage.

STROBE LIGHT REPLACEMENT

WARNING: Make sure strobe unit is not plugged into electric outlet.

1. Grasp strobe light bulb and reflector and pull light from its socket.

NOTE: It may be necessary to pry light from its socket with a screwdriver placed under reflector lip.

2. Plug replacement strobe (Part No. 60211) into tube socket, making sure strobe light is pushed all the way into the socket.

TROUBLESHOOTING

STROBE UNIT P.C. BOARD

The strobe unit p.c. board is a non-serviceable assembly supplied as shown below. External circuit connections are made by two 24 pin plug connectors referenced P1 and P2. Connector P1 couples the power transformer secondary a.c. voltages to the board, and d.c. voltages and ground to the flash tube. Connector P2 provides external connections to the vibration sensor, meter, strobe, and meter sensitivity switches.

The transformer secondary a.c. voltages are rectified and filtered by board components. D.C. voltages provided are regulated +18, zener regulated +9, and

unregulated +170 and +560 volts. Functions of the amplifier circuits are explained in the principles of operation section.

Offset null potentiometer R3 is the only adjustment on the board. It is adjusted for zero meter reading with the vibration pick-up disconnected and a short connected across contacts 1 and 2 of connector P3 at rear of the strobe unit.

To replace the assembly, remove connectors P1 and P2 and four screws securing the board to the strobe unit.

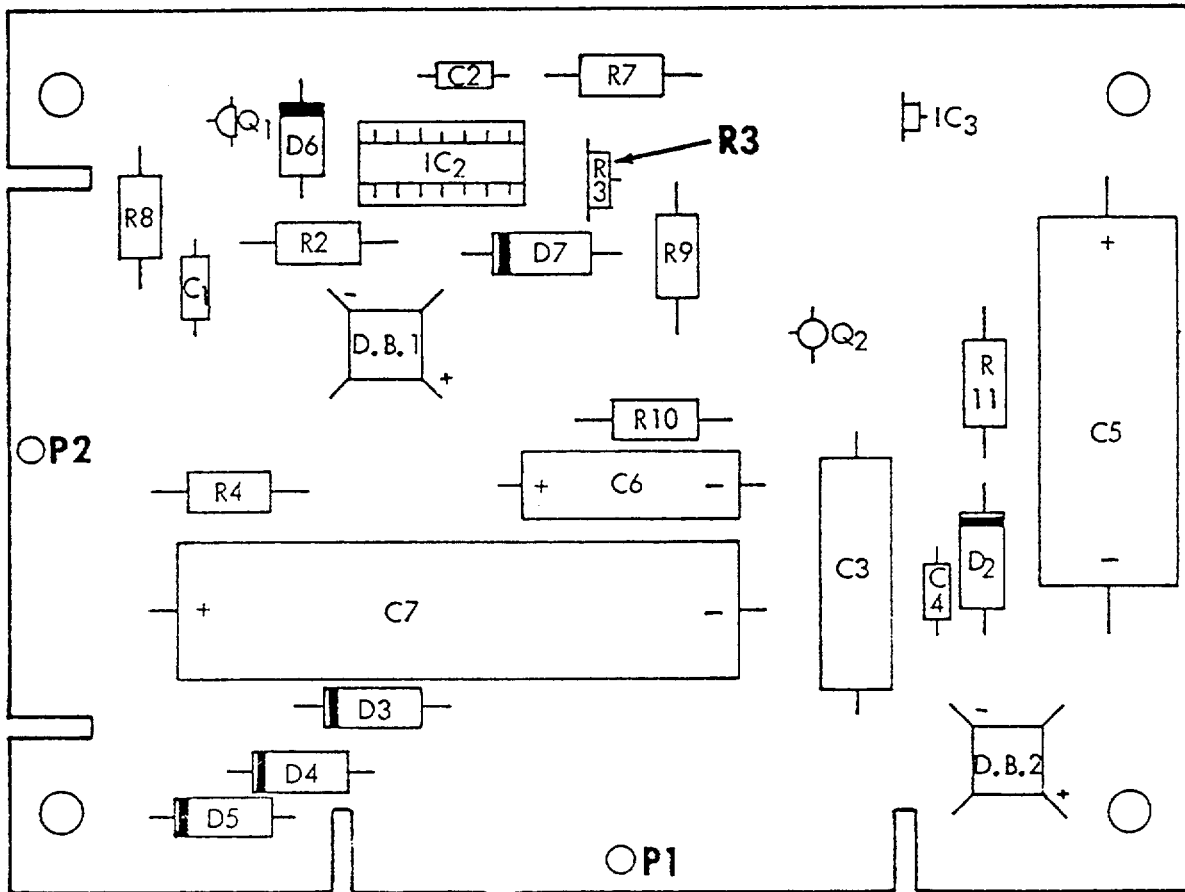

Figure 14. Strobe Unit P.C. Board 60589

TROUBLESHOOTING (cont)

VIBRATION SENSOR P.C. BOARD

This printed circuit board is a non-serviceable assembly and is supplied as shown in the drawing. External circuit connection to the strobe unit is by white, green and black wires (part of multiconductor cable) soldered to the board.

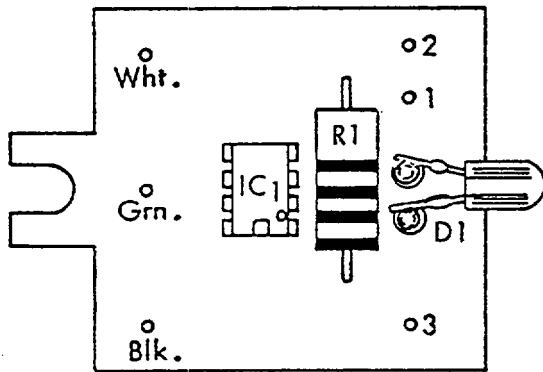

Figure 15. Vibration Sensor P.C. Board 60265

Lead wires 2, 1 and 3 connect to the light sensor potentiometer which is part of the vibration sensor assembly.

The primary board functions are to provide a light source via the LED for the light sensor potentiometer, and to provide a buffer amplifier input for the light sensor signal. Output from the buffer amplifier drives the meter amplifier in the strobe unit.

The housing must be removed from the assembly to gain access to the p.c. board. Remove 3 round head machine screws securing cover, and 2 screws adjacent to the cable securing the sub-assembly. Unsolder 6 leads and remove one screw securing the board.

HOW TO SERVICE CONNECTORS

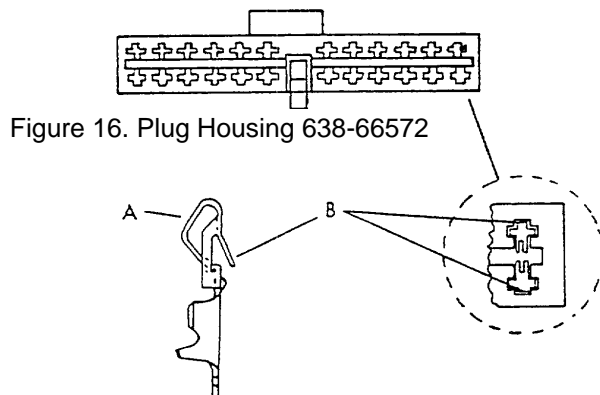

Figure 16. Plug Housing 638-66572

This is a 24 contact p.c. board connector with one contact shown For illustration. All contacts should spread uniformly to assure contact with all p.c. board pins. Contacts may be bent out by inserting a small tool or piece of bent wire (F) under contact at (A) and carefully lifting slightly upward. If contacts or board pins look corroded or dirty, they may be restored with a commercial contact cleaner.

To remove a broken or defective contact, a flat, narrow tool or piece of metal must be inserted between plug housing and rear edge of contact at (B). This depresses the spring retaining clip at (B) and allows contact to be pulled out the wire end of plug.

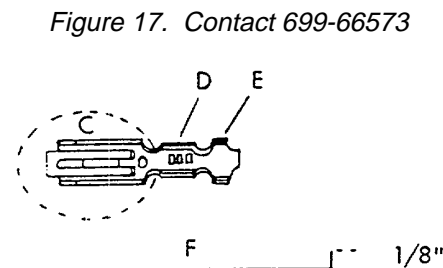

Figure 17. Contact 699-66573

A new contact is installed by tinning both the contact and wire using a light, low-heat soldering iron. CAUTION: Solder must not be present in circled area (C) of contact. Bend tabs (D) over wire and apply minimal heat at (D). Bend tabs (E) over wire insulation.

TROUBLESHOOTING (cont.)**TROUBLESHOOTING NOTES**

1. A meter reading off scale without a signal into the unit is an indication of a defective strobe unit p.c. board 60589. Replace board and adjust pot R3 for zero meter reading with a short placed across input. (Refer p.c. board description.)
2. If the meter responds to signal levels but the strobe does not flash, the cause may be:
 - a. Defective strobe switch -- connect a jumper across switch to check. Momentarily grounding the anode (case) of SCR (Q2) should flash the strobe. If not:
 - b. The SCR may be shorted -- replace p.c. board 60589.
 - c. The high voltage supplies (170 vdc and 560 vdc) may be inoperative. Check transformer. Replace 60598 if necessary; check P.C. board assembly and replace 660589 if necessary.
 - d. The strobe tube may be defective. Replace strobe tube 60211.
3. If a problem is encountered with screws in the vibration pick-up assembly coming loose, apply Thread-Locking Compound (NSN 8030-00-829-4554) and retighten.

SERVICE PARTS LIST

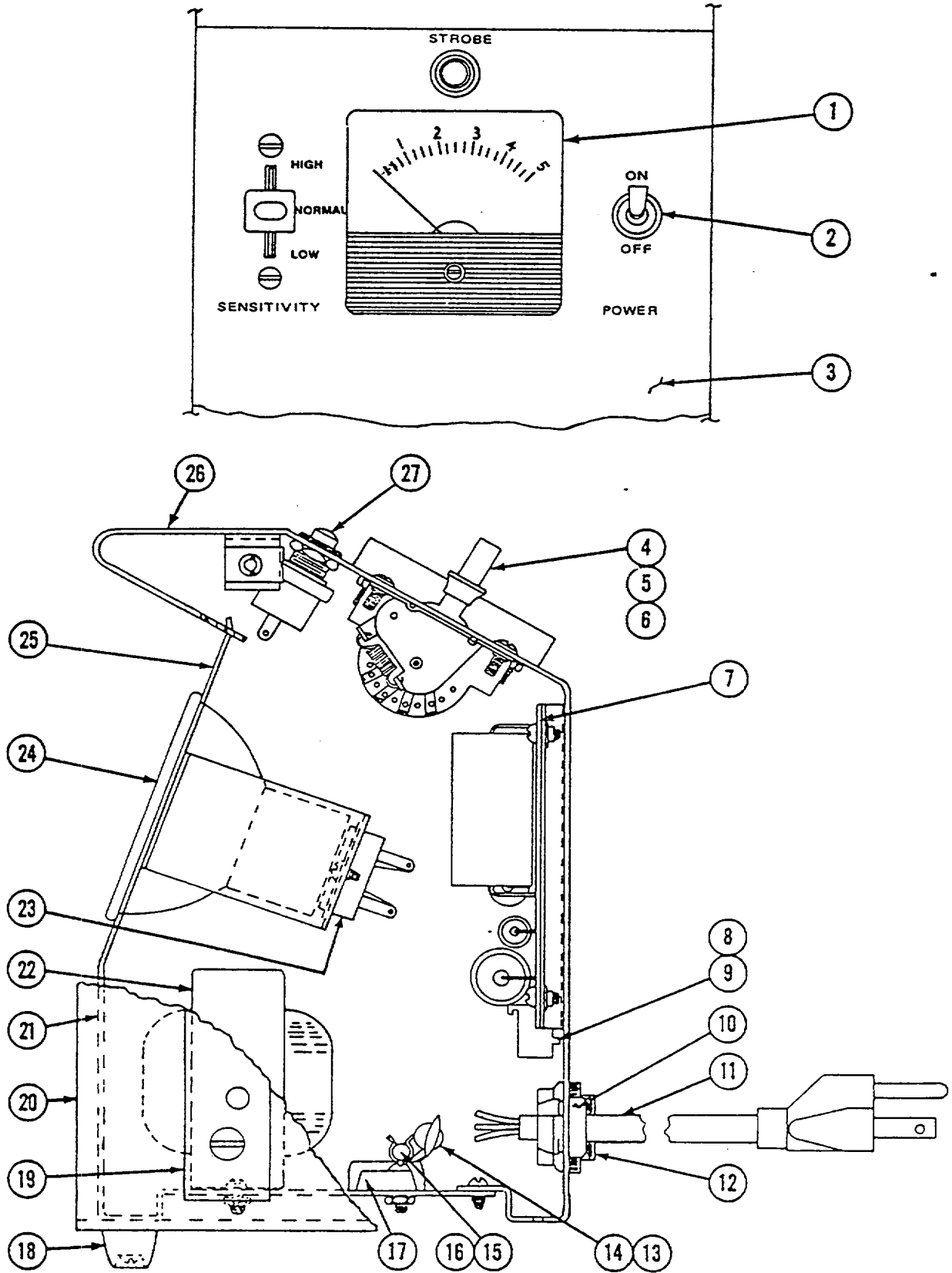

Figure 18. Strobe Unit

SERVICE PARTS LIST

ITEM	PART NO.	DESCRIPTION
1	60191	Meter
2	60195	Switch, Power
3	60678	Decal, Instruction
4	60177	Switch, Sensitivity - Includes: 5, 6
5	60368	R5-68 Ohm 1/2 Watt Resistor
6	60369	R6-180 Ohm 1/2 Watt Resistor
7	60589	P.C. Board Assembly
8	60583	P.C. Edge Connector
9	60584	Contact
10	60301	Strain Relief Bushing
11	60825	A. C. Cord
12	58495	Connector, Female
13	60224	Voltage Suppressor
14	60302	1000 Ohm 12 Watt Resistor
15	50657	Fuse
16	60199	Fuse Clip
17	60592	Terminal Block
18	60246	Bumper
19	60569	Handle
20	60568	Case, Frame
21	60679	Product Decal
22	60598	Transformer Assembly
23	30111	Tube Socket
24	60211	Flash Tube w/Face Cover
25	60593	Front Wrapper Weld Assembly
26	60586	Rear Wrapper Weld Assembly
27	60223	Switch, Strobe

SERVICE PARTS LIST

VIBRATION PICK-UP ASSEMBLY

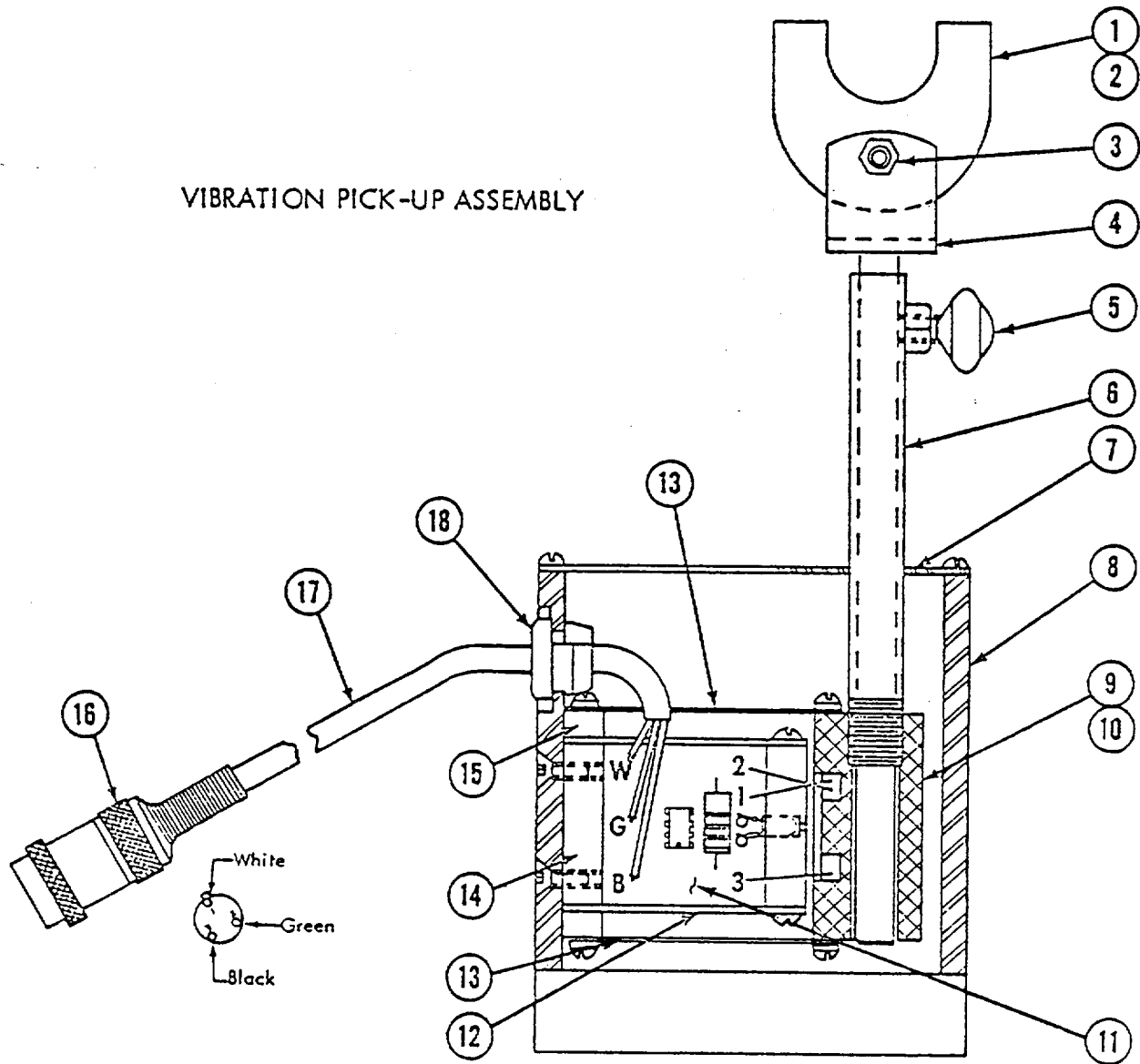

ITEM	PART NO.	DESCRIPTION	ITEM	PART NO.	DESCRIPTION
1	60263	Magnet-Rod Ass'y., Includes 2,3,4	9	60602	Sensor Sub-Ass'y., Includes: 10,11,12,13,14,15,17
2	60262	Magnet	10	60272	Block-Potentiometer Ass'y.
3	11007	Set Screw	11	60265	P.C. Board Ass'y.
	9589	Hex Nut	12	60266	Plate
4	60261	Rod & Bracket Weldment	13	60276	Leaf Spring
5	9828	1/4 X 20 X 1/2 Thumb Screw	14	60267	Block
6	60249	Guide Tube Weldment	15	60274	Spacer
7	60283	Cover	16	50854	Male Connector
8	60281	Housing Weldment	17	60273	Pick-Up Cable
			18	23570	Strain Relief Bushing

Figure 19. Vibration Pick-up Assembly

By Order of the Secretary of the Army:

E. C. MEYER
General, United States Army
Chief of Staff

Official:

ROBERT M. JOYCE
Major General, United States Army
The Adjutant General

DISTRIBUTION:

To be distributed in accordance -with Special Mailing List.

U.S. GOVERNMENT PRINTING OFFICE: 1985 - 461-202/11779

RECOMMENDED CHANGES TO EQUIPMENT TECHNICAL PUBLICATIONS



THEN... JOT DOWN THE DOPE ABOUT IT ON THIS FORM, CAREFULLY TEAR IT OUT, FOLD IT AND DROP IT IN THE MAIL!

SOMETHING WRONG WITH THIS PUBLICATION?

FROM: (PRINT YOUR UNIT'S COMPLETE ADDRESS)

DATE SENT

PUBLICATION NUMBER

PUBLICATION DATE

PUBLICATION TITLE

BE EXACT... PIN-POINT WHERE IT IS

PAGE NO.

PARA-GRAPH

FIGURE NO.

TABLE NO.

IN THIS SPACE TELL WHAT IS WRONG AND WHAT SHOULD BE DONE ABOUT IT:

TEAR ALONG PERFORATED LINE

PRINTED NAME, GRADE OR TITLE, AND TELEPHONE NUMBER

SIGN HERE:

DA FORM 2028-2
1 JUL 79

PREVIOUS EDITIONS ARE OBSOLETE.

P.S.—IF YOUR OUTFIT WANTS TO KNOW ABOUT YOUR RECOMMENDATION MAKE A CARBON COPY OF THIS AND GIVE IT TO YOUR HEADQUARTERS.

THE METRIC SYSTEM AND EQUIVALENTS

LINEAR MEASURE

1 Centimeter = 10 Millimeters = 0.01 Meters = 0.3937 Inches
 1 Meter = 100 Centimeters = 1000 Millimeters = 39.37 Inches
 1 kilometer = 1000 Meters = 0.621 Miles

WEIGHTS

1 Gram = 0.001 Kilograms = 1000 Milligrams = 0.035 Ounces
 1 Kilogram = 1000 Grams = 2.2 Lb.
 1 Metric Ton = 1000 Kilograms = 1 Megagram = 1.1 Short Tons

LIQUID MEASURE

1 Milliliter = 0.001 Liters = 0.0338 Fluid Ounces
 1 Liter = 1000 Milliliters 33.82 Fluid Ounces

SQUARE MEASURE

1 Sq. Centimeter = 100 Sq. Millimeters = 0.155 Sq. Inches
 1 Sq. Meter = 10,000 Sq. Centimeters = 10.76 Sq. Feet
 1 Sq. Kilometer = 1,000,000 Sq. Meters = 0.386 Sq. Miles

CUBIC MEASURE

1 Cu. Centimeter = 1000 Cu. Millimeters = 0.06 Cu. Inches
 1 Cu. Meter = 1,000,000 Cu. Centimeters = 35.31 Cu. Feet

TEMPERATURE

$5/9 (^{\circ}\text{F} - 32) = ^{\circ}\text{C}$
 212° Fahrenheit is equivalent to 100° Celsius
 90° Fahrenheit is equivalent to 32.2° Celsius
 32° Fahrenheit is equivalent to 0° Celsius
 $9/5 (^{\circ}\text{C} + 32) = ^{\circ}\text{F}$

APPROXIMATE CONVERSION FACTORS

TO CHANGE

Inches
 Feet.....
 Yards
 Miles
 Square Inches.....
 Square Feet
 Square Yards
 Square Miles.....
 Acres.....
 Cubic Feet.....
 Cubic Yards
 Fluid Ounces.....
 Pints.....
 Quarts
 Gallons.....
 Ounces.....
 Pounds.....
 Short Tons
 Pound-Feet
 Pounds per Square Inch.....
 Miles per Gallon
 Miles per Hour.....

TO

Centimeters.....
 Meters
 Meters
 Kilometers
 Square Centimeters
 Square Meters.....
 Square Meters.....
 Square Kilometers.....
 Square Hectometers
 Cubic Meters
 Cubic Meters
 Milliliters
 Liters
 Liters
 Liters
 Grams
 Kilograms
 Metric Tons
 Newton-Meters.....
 Kilopascals
 Kilometers per Liter
 Kilometers per Hour

MULTIPLY BY

2.540
 0.305
 0.914
 1.609
 6.451
 0.093
 0.836
 2.590
 0.405
 0.028
 0.765
 29.573
 0.473
 0.946
 3.785
 28.349
 0.454
 0.907
 1.356
 6.895
 0.425
 1.609

TO CHANGE

Centimeters.....
 Meters.....
 Meters
 Kilometers
 Square Centimeters
 Square Meters.....
 Square Meters.....
 Square Kilometers.....
 Square Hectometers
 Cubic Meters.....
 Cubic Meters.....
 Milliliters
 Liters
 Liters
 Liters
 Grams
 Kilograms
 Metric Tons
 Newton-Meters.....
 Kilopascals
 Kilometers per Liter
 Kilometers per Hour

TO

Inches
 Feet.....
 Yards.....
 Miles.....
 Square Inches
 Square Feet
 Square Yards
 Square Miles
 Acres.....
 Cubic Feet.....
 Cubic Yards.....
 Fluid Ounces
 Pints.....
 Quarts
 Gallons.....
 Ounces.....
 Pounds.....
 Short Tons
 Pound-Feet
 Pounds per Square Inch.....
 Miles per Gallon
 Miles per Hour.....

MULTIPLY BY

0.394
 3.280
 1.094
 0.621
 0.155
 10.764
 1.196
 0.386
 2.471
 35.315
 1.308
 0.034
 2.113
 1.057
 0.264
 0.035
 2.205
 1.102
 0.738
 0.145
 2.354
 0.621

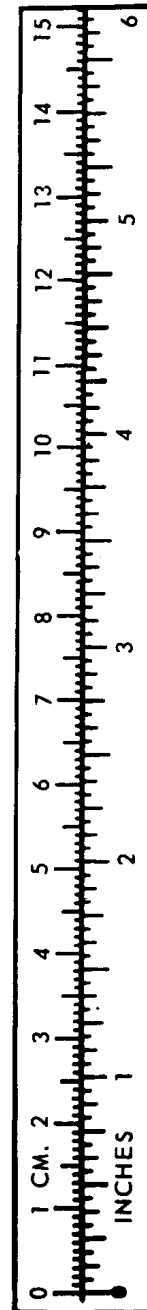

TM 9-4910-625-14&P BALANCER, WHEEL VEHICLE: ELECTRONIC MODEL 814 TITAN INDUSTRIES [4910-00-279-0629] 1983

PIN: 052767-000